

4341 SRM87

4 CYLINDERS IN LINE - DIESEL CYCLE
64 kW (87 HP) @ 3200 rpm (A1)

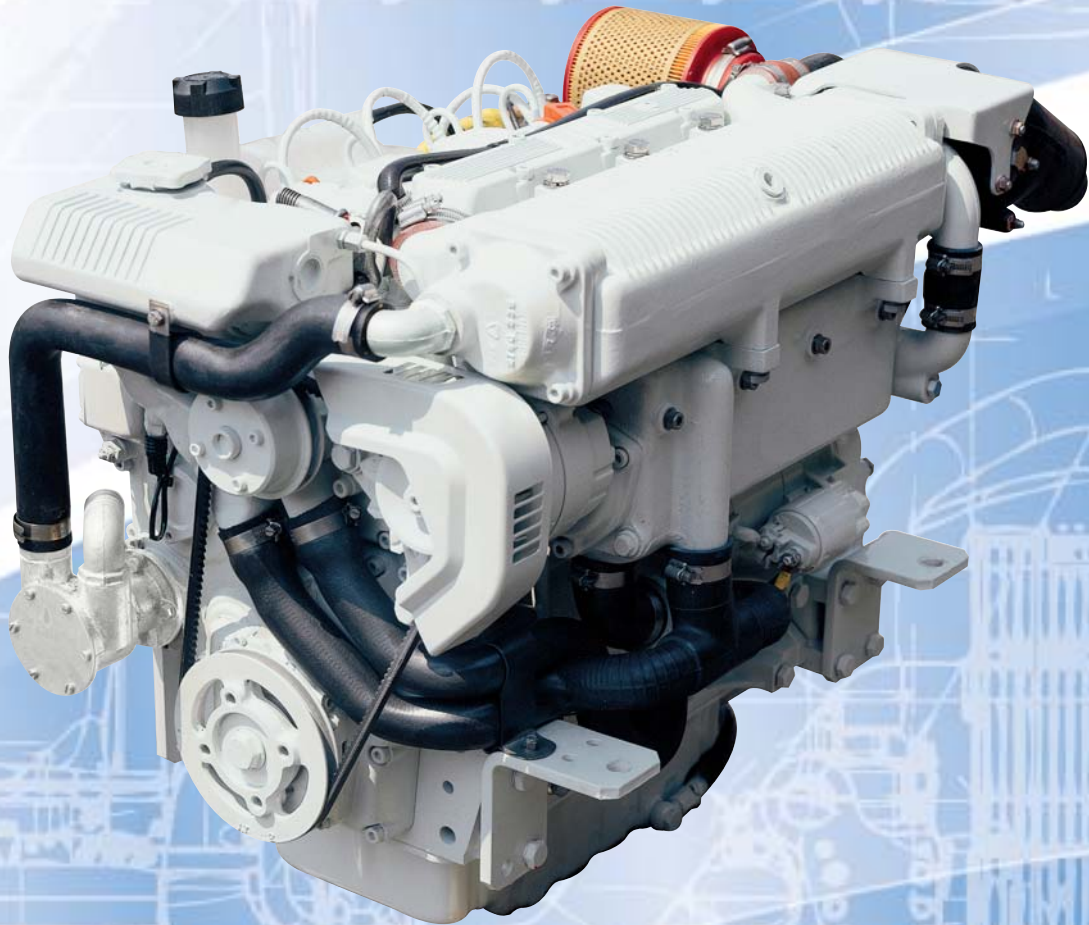

MARINE APPLICATIONS

4341 SRM87 FOR MARINE APPLICATIONS

Thermodynamic cycle		Diesel 4 stroke
Air intake		TAA
Arrangement		4L
Bore x Stroke	mm	88 X 90,4
Total displacement	l	2.199
Valves per cylinder		2
Cooling		liquid
Direction of rotation (viewed facing flywheel)		CCW
Engine management		mechanical
Injection system		mechanical pump

Electrical system

Voltage	V	12
---------	---	----

Standard configuration

Flywheel housing	type	SAE 6
Flywheel size	inch	7 1/2
Air filter		dry
Turbocharger		with waste gate
Heat exchanger		tube type
Exhaust cooled elbow		nodular cast iron Ø 75 mm
Water charge tank		included
Fuel filter	n°	1 - rear side
Fuel prefilter		–
Fuel pump		included
Oil filter	n°	1 - left side
Oil sump		pressed steel with corrosion inhibiting treatment
Oil vapours blow-by circuit		yes
Oil heat exchanger		yes
Oil filler		on timing cover frontward
Starting motor		12 V - 2.2 kW
Alternator		12 V - 65 A
Engine stop device		electrical excitation
Wiring harness		wiring harness and electrical panel
Painting	colour	white "ICE"

Not included in the standard configuration

Battery - minimum capacity recommended		88 Ah
Battery - minimum cold cranking capacity recommended		–

FPT OFFERS THE WIDEST AVAILABILITY OF ENGINE BUILD OPTIONS TO CUSTOMER SPECIFIC REQUIREMENTS WITHIN THE ENGINE SUPPLY. TO FIND OUT MORE ABOUT THE CONFIGURATIONS AND ACCESSORIES WHICH ARE AVAILABLE, CONTACT THE FPT SALES NETWORK.

4341 SRM87 FOR MARINE APPLICATIONS

Rating type		A1
Maximum power *	kW(HP)	64 (87)
At speed	rpm	3200
Maximum no load governed speed at max rating	rpm	3400
Minimum idling speed	rpm	850 ± 50
Mean piston speed at rated speed	m/s	9.6
BMEP at max torque	kg/cm ²	12.23
Available certifications		-
Specific fuel consumption at full load (best value)	g/kWh @ rpm	252 @ 2000
Oil consumption at max rating	(% of fuel consumption)	≤ 0.2
Minimum starting temperature without auxiliaries	°C	- 10
Oil and oil filter maintenance interval for replacement	hours	250 oil / 125 filters

* **Net Power** at flywheel according to ISO 3046/1, after 50 hours running, fuel Diesel EN 590. Power tolerance 5%.

Test conditions: ISO 3046/1, 25 °C air temperature, 100 kPa atmospheric pressure, 30% relative humidity.

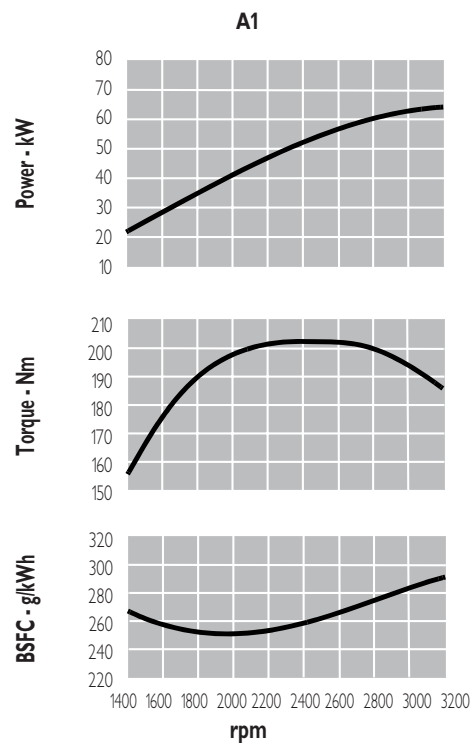

A1 = High performance crafts.
 Full throttle operation restricted within 10% of total use period.
 Cruising speed at engine rpm < 90% of rated speed setting - Maximum useage 300 hours per year.

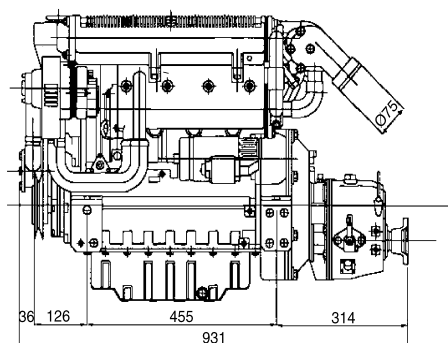
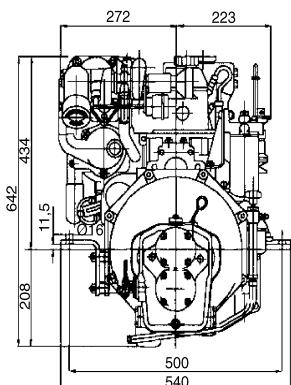

Dry weight (without marine gear) = 255 kg

ENGINE BENEFITS

- **PERFORMANCE:** Ratings, consumption and emissions optimisation due to indirect injection and specific mechanical engine management; lightness; compactness; high torque at low rpms.
- **SERVICEABILITY:** Widespread and quick service; easy maintenance.
- **RELIABILITY:** Compact and functional design.
- **ENVIRONMENTALLY FRIENDLY:** Noise, gaseous emissions and vibrations reduction.
- **CUSTOMER ORIENTATION:** Sail-drive and accessories range availability.

FIAT POWERTRAIN TECHNOLOGIES

Via Puglia, 15 - 10156 Torino

FIAT POWERTRAIN TECHNOLOGIES

Viale dell'Industria, 15/17 - 20010 Pregnana Milanese (MI)

www.ftpowertrain.com

LOCAL DISTRIBUTOR