

4031 M30

FOR MARINE APPLICATIONS
3 CYLINDERS IN LINE - DIESEL CYCLE
22.1 kW (30 CV) @ 3600 rpm (A1)



T E C H N O L O G I C A L E X C E L L E N C E

IVECO
MOTORS

4031 M30 FOR MARINE APPLICATIONS

| | | |
|--|------------------|------------------------|
| Thermodynamic cycle | | Diesel 4 stroke - D.I. |
| Air intake | | NA |
| Arrangement | | 3L |
| Bore x Stroke | mm | 75 X 77.6 |
| Total displacement | l | 1.028 |
| Valves per cylinder | | 2 |
| Cooling | | liquid |
| Direction of rotation (viewed facing flywheel) | | CCW |
| Compression ratio | | 22.8 : 1 |
| Rotation mass moment of inertia (without flywheel) | kgm ² | - |
| Standard flywheel inertia | kgm ² | 0.064 |

Air induction

| | | |
|---|--------------------------|-------------|
| Max suggested intake restriction with clean air filter | kPa(bar) | 3.5 (0.035) |
| Max allowable restriction with dirty air filter | kPa(bar) | - |
| Air requirement for combustion at 100% load/rated speed (comb. + ventilation) | kg/h (m ³ /h) | 130 (111) |
| Turbocharging pressure at full load/rated speed | kPa(bar) | - |
| Turbocharging air max temperature (engine inlet) | °C | - |

Exhaust system

| | | |
|--|----------|-------------|
| Max allowable backpressure | kPa(bar) | 14.6 (0.14) |
| Max exhaust temperature at maximum power | °C | 580 |
| Exhaust flow at max output | kg/h | 139 |

Lubrication system

| | | |
|--|----------|----------|
| Minimum oil pressure at idle (at 100°C) | kPa(bar) | 70 (0.7) |
| Max oil temperature at full load/rated speed | °C | 130 |
| Engine angularity limits continuous operation: max front up and front down | 0/360 | 25 |
| max left hand and right hand | 0/360 | 25 |
| Total system capacity including pipes, filters etc. | liters | 3 |

Sea water cooling system (open circuit)

| | | |
|------------------------------------|-------------------|---------------|
| Max intake restriction | kPa(bar) | 50 (0.5) |
| Sea water pump flow | m ³ /h | 1.5 |
| Heat rejected (total) at max power | kJ/s(kcal/h) | 18.9 (16,200) |
| Sacrificial zinc anodes | n° | 1 |

Cooling system (closed circuit)

| | | |
|--|-------------------|---------|
| Coolant capacity (engine only) | liters | 3 |
| Water pump flow at rated speed | m ³ /h | 2.7 |
| Thermostat (modulating range) | °C | 80 ÷ 95 |
| Cooling liquid max temperature | °C | 88 |
| Min/max inner pressure in the cooling circuit (for keel cooling) | kPa(bar) | - |
| External cooling system max pressure drop (for keel cooling) | kPa(bar) | - |

Fuel system

| | | |
|--------------------------------|----------|----------------|
| Injection system | | Unit Injection |
| Gas oil max intake restriction | kPa(bar) | - |
| Gas oil max intake temperature | °C | 60 |
| Max fuel backpressure to tank | kPa(bar) | 20 (0.2) |

Electrical system

| | | |
|---------|---|----|
| Voltage | V | 12 |
|---------|---|----|

4031 M30 FOR MARINE APPLICATIONS

| | | |
|---|-------------------------|-----------------------|
| Rating type | | A1 |
| Maximum power * | kW(CV) | 22.1 (30) |
| At speed | rpm | 3600 |
| Maximum no load governed speed at max rating | rpm | 3850 |
| Minimum idling speed | rpm | 850 ± 50 |
| Mean piston speed at rated speed | m/s | 9.3 |
| BMEP at max torque | kg/cm ² | 7.56 |
| Available certifications | | - |
| Specific fuel consumption at full load (best value) | g/kWh @ rpm | 256 @ 2400 |
| Oil consumption at max rating | (% of fuel consumption) | ≤ 0.2 |
| Minimum starting temperature without auxiliaries | °C | - 20 |
| Oil and oil filter maintenance interval for replacement | hours | 250 oil / 125 filters |
| Dry weight (without marine gear) | kg | 115 |

* **Net Power** at flywheel according to ISO 3046/1, after 50 hours running, fuel Diesel EN 590. Power tolerance 5%
Test conditions : ISO 3046/1, 25 °C air temperature, 100 kPa atmospheric pressure, 30 % relative humidity.

A1

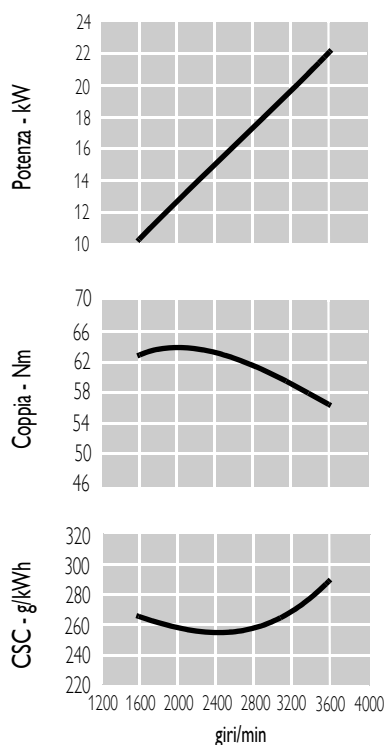

A1 = High performance crafts.
 Full throttle operation restricted within 10% of total use period.
 Cruising speed at engine rpm < 90% of rated speed setting - Maximum usage 300 hours per year.

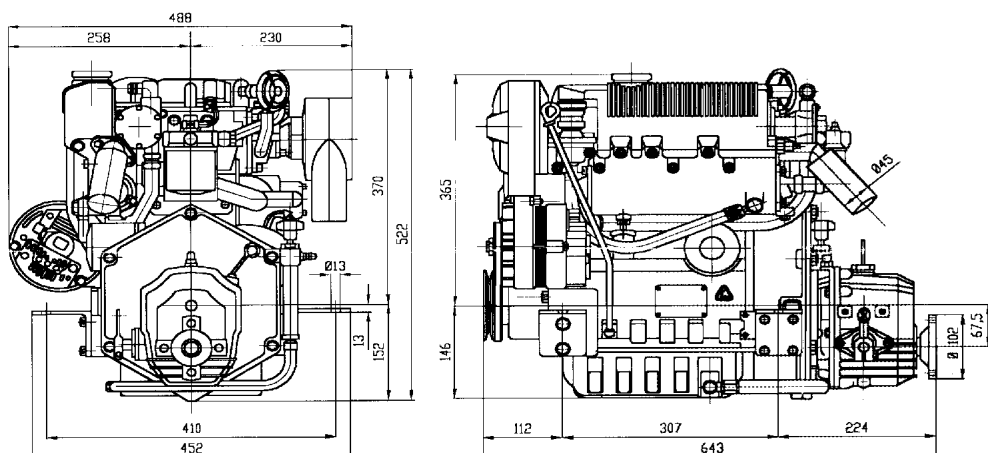

4031 M30 FOR MARINE APPLICATIONS

Standard configuration

| | | |
|-----------------------------|--------|---|
| Flywheel housing | SAE | B |
| Flywheel size | inch | alignment, flexible coupling Ø 121.5 mm |
| Air filter | | dry |
| Turbocharger | | - |
| Heat exchanger | | tube type |
| Exhaust cooled elbow | | stainless steel Ø 45 mm |
| Water charge tank | | included |
| Fuel filter | n° | 1 - rear side |
| Fuel prefilter | | - |
| Fuel pump | | included |
| Oil filter | n° | 1 - left side |
| Oil sump | | pressed steel with corrosion inhibiting treatment |
| Oil vapours blow-by circuit | | yes |
| Oil heat exchanger | | - |
| Oil filler | | on timing cover frontward |
| Starting motor | | 12 V - 1.1 kW |
| Alternator | | 12 V - 65 A |
| Engine stop device | | electrical excitation |
| Wiring harness | | wiring harness and electrical panel |
| Painting | colour | white "ICE" |

Not included in the standard configuration

| | | |
|--|--|-------|
| Battery - minimum capacity recommended | | 66 Ah |
| Battery - minimum cold cranking capacity recommended | | - |

IVECO MOTORS OFFERS THE WIDEST AVAILABILITY OF ENGINE BUILD OPTIONS TO CUSTOMER SPECIFIC REQUIREMENTS WITHIN THE ENGINE SUPPLY. TO FIND OUT MORE ABOUT THE CONFIGURATIONS AND ACCESSORIES WHICH ARE AVAILABLE, CONTACT THE IVECO MOTORS SALES NETWORK.

HEAD OFFICE AND BRANCHES

| | | | |
|---|-----------------------------|---|-----------------------------|
| <p>IVECO S.p.A. Iveco Motors Lungo Stura Lazio, 49 - 10156 Torino Tel. +39 (011) 0076245 - Fax +39 (011) 0076275 www.ivecomotors.com</p> | <p>Italy</p> | <p>IVECO S.p.A. Iveco Motors Viale dell'Industria, 15/17 - 20010 Pregnana Milanese - Milano Tel. +39 (02) 935101 - Fax +39 (02) 93590029</p> | <p>Italy</p> |
| <p>IVECO FRANCE S.A. Iveco Motors 50 Rue Ampère - B.P. 103 - 69685 Chassieu Cedex Tel. +33 (04) 72472222 - Fax +33 (04) 78905990</p> | <p>France</p> | <p>IVECO N.V. Iveco Motors - Liaison office-India Second Floor - 50, Okhla Industrial Estate - Phase III 110020 New Delhi Tel. +91 11 51613573 - Fax +91 11 26931271</p> | <p>India</p> |
| <p>IVECO MAGIRUS A.G. Iveco Motors Heiner Fleischmann-Strasse, 9 - 74172 Neckarsulm Tel. +49 (07132) 97690 - Fax +49 (07132) 976935</p> | <p>Germany</p> | <p>IVECO FIAT Representative Office in P.R. China 10/F Jinling Hotel World Trade Center 2 Hanzhong Road - 210005 Nanjing. Tel. +86 25 4710981 - Fax +86 25 4701105</p> | <p>China</p> |
| <p>IVECO U.K. Ltd Iveco Motors Road One - Industrial Estate CW7 3QP Winsford Tel. +44 (01606) 541027 - Fax +44 (01606) 541124</p> | <p>Great Britain</p> | <p>IVECO LATIN AMERICA Ltda. Iveco Motors Rua Alameda da Serra, 222 Vale do Sereno - 34000 - 000 Nova Lima (MG) Tel. +55 31 3286 3732/33134 - Fax +55 31 3286 3735</p> | <p>Brazil</p> |
| <p>IVECO SWEDEN A.B. Iveco Motors Lergöskgatan, 12 - 42150 Västra Frölunda Tel. +46 (31) 492450 - Fax +46 (31) 492457</p> | <p>Sweden</p> | <p>IVECO Motors of N.A. 245 E. North Avenue Carol Stream, IL 60188 - 2021 USA Tel. +1 630 260 4226 - Fax +1 630 260 4267</p> | <p>North America</p> |

Local Distributor